

GIANO

PLUG IN TOTAL MODULARITY



GALILEI
REFRIGERAZIONE & DESIGN

GIANO È ESPRESSIONE DEL PROGETTO **VI.DE.RE.** VISIBILITY, DESIGN, RELIABILITY

GIANO HAS BEEN DEVELOPED ACCORDING TO PROJECT **VI. DE. RE.**
VISIBILITY, DESIGN, RELIABILITY

GIANO EST L'EXPRESSION DU CONCEPT **VI. DE. RE.**
VISIBILITÉ, DESIGN, FIABILITÉ

GIANO WURDE IM RAHMEN DES PROJEKTES **VI. DE. RE.**
ENTWICKELT VISIBILITY, DESIGN, RELIABILITY

GIANO HA SIDO DESARROLLADO DE ACUERDO AL PROYECTO **VI. DE. RE.**
VISIBILIDAD, DISEÑO, FIABILIDAD



Giano 70 VD GD 937



Giano 70 Maxi 1250



Giano 70 VD 937



Giano 70 Maxi 1875



3M0 (-1/4°C), 3M1 (-1/5°C), 3M2 (-1/7°C)



TRASPARENZA DELLE SUPERFICI
Per una visione completa di tutta la merce esposta

RIGORE DELLE FORME
Forme semplici, merce in primo piano

PIÙ PRODOTTO ESPOSTO
Per metro quadrato di superficie grande capacità di carico con ingombri ridotti

FACILITÀ DI INTEGRAZIONE
In ogni tipologia di negozio possibilità di combinare più mobili. Regolabile in altezza e inclinazione

CONSUMI ENERGETICI RIDOTTI
Valvola termostatica, ventilatori elettronici, alto isolamento termico, dimensionamento generoso dell'evaporatore

LUNGA DURATA DEL BANCO
Lamieraggi interni in acciaio zincato e verniciato a polveri, evaporatore protetto contro la corrosione, componenti di prima qualità

BASSI COSTI DI INSTALLAZIONE
Protezione elettrica magneto-termica e differenziale di serie

FACILITÀ DI PULIZIA
Componenti facilmente smontabili

*La classificazione energetica si riferisce a precise configurazioni del prodotto. Per maggiori informazioni consultare il Registro Europeo dei Prodotti. per l'Etichettatura Energetica EPREL o contattare i nostri Uffici Commerciali



COMPLETE TRANSPARENCY
Of the upper section, allowing for excellent visual merchandising

SIMPLE AND SHARP LINES
Sober and elegant shapes, product in foreground

HIGHEST FOOTPRINT PRODUCTIVITY
More food in a small cabinet

EASY TO INTEGRATE
In any store format. Adjustable in height and inclination

REDUCED ENERGY CONSUMPTION
Expansion valve, EC-fans, highest thermal insulation, big evaporator

LONG LIFE OF THE CABINET
All metal parts inside the case in galvanized and fully coated steel, evaporator protected against corrosion, first quality components

LOW INSTALLATION COSTS
The RCBO switch in the standard equipment

SIMPLE TO CLEAN
All components easy to disassemble

*The energy classification refers to precise product configurations. For more information, please consult the European Product Database for Energy Labelling (EPREL) or contact our Sales Office



TRANSPARENCE TOTALE
Visibilité parfaite des denrées exposées

DESIGN ÉPURÉ
Esthétique sobre et élégante, mise en avant des denrées

TRÈS BONNE RENTABILITÉ
Grand volume de chargement par rapport à l'emprise au sol

FACILITE D'INTEGRATION
Adapté à tout type de magasin. Inclinaison

CONSOMMATION TRÈS FAIBLE
Détendeur thermostatique à égalisation externe de pression, ventilateurs électroniques, évaporateurs de grande taille, isolation renforcée, compresseurs parfaitement adaptés.

GRANDE LONGÉVITÉ
Composants techniques de grande fiabilité et construction très soignée

FAIBLE COUT D'INSTALLATION
La protection électrique différentielle est intégrée dans la vitrine

GRANDE FACILITÉ DE NETTOYAGE
Tous les composants se démontent très facilement

*La classification énergétique fait référence à des configurations détaillées du produit. Pour plus d'informations, consultez le Registre Européen des Produits pour l'Etiquetage Énergétique EPREL ou contactez notre Service Commercial



EINE VOLLSTÄNDIGE TRANSPARENZ
Im oberen Bereich erlaubt eine exzellente Warenpräsentation

EINFACHE UND KLARE FORMEN
Sowie ein schlichtes und elegantes Design lässt die Ware im Vordergrund stehen

HÖCHSTE WARENPRÄSENTATION-FLÄCHE
Mehr Ware in kleinen Möbeln

LEICHT ZU INTEGRIEREN IN ALLEN LADENFORMATE
In Höhe und Neigung verstellbar, anreihfähig

REDUZIERTER ENERGIEVERBRAUCH
Thermostatische Expansionsventile, hervorragende Dämmung, große Verdampfer

LANGE LEBENSDAUER DES MÖBELS
Alle Metallteile im Inneren des Gehäuses aus verzinktem und vollständig pulverbeschichtetem Stahl, Verdampfer gegen Korrosion geschützt, erstklassigen Komponenten

GERINGE INSTALLATIONS-AUFWAND
FI-Schutzschalter (Personenschutz) ist Standard

EINFACHE REINIGUNG
Alle Komponenten sind einfach zu demontieren

*Die Energieklasse bezieht sich auf spezifische Produktkonfigurationen. Weitere Informationen können Sie in der Europäischen Produktdatenbank für Energiekennzeichnung (EPREL) erhalten oder bei unseren Vertriebsbüros



TOTAL TRANSPARENCIA
Permitiendo una visión excelente de todo el producto

LINEAS SIMPLES, RIGUROSAS
Formas sobrias y elegantes, para mostrar el producto en primer plano

MÁS PRODUCTO EXPUESTO
Por ocupación en suelo

FACILIDAD DE INTEGRACIÓN
A cualquier tipo de negocio. Ajustable en altura e inclinación

REDUCIDO CONSUMO ENERGÉTICO
Válvula termostática, ventiladores ec, alto aislamiento térmico, generoso evaporador

MUEBLE DE MÁS LARGA VIDA
Todas las partes metálicas internas en acero galvanizado y barnizadas al polvo, evaporador protegido a la corrosión, componentes de alta calidad

BAJO COSTE DE INSTALACIÓN
Magnetotérmico y diferencial incluidos

FACILIDAD DE LIMPIEZA
Todos los componentes son de fácil extracción

*La clasificación energética se refiere a configuraciones precisas del producto. Para más información, consulte el Registro Europeo de Productos con Etiquetado Energético EPREL o ponerse en contacto con nuestro Departamento Comercial

Biologico

LE OFFERTE
DEL GIORNO

~ Pasticcio ~
~ Involtini ~
~ Salumi ~

Cibi pronti

GALILEI PLUG IN LINE

1
PROGETTO

4
MODELLI

40
MODULI

∞
COMBINAZIONI



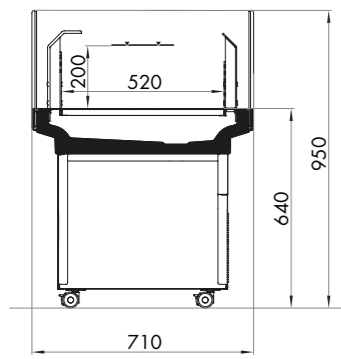

GIANO 50 VD

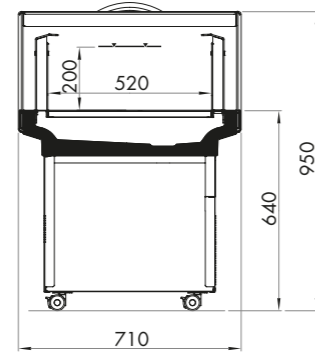

GIANO 50 VD GD

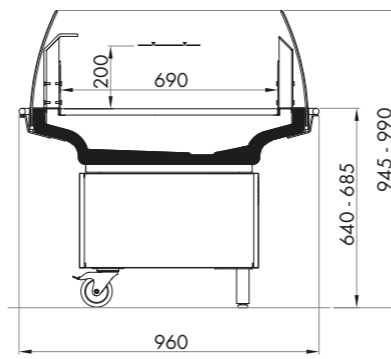

GIANO 70 VC

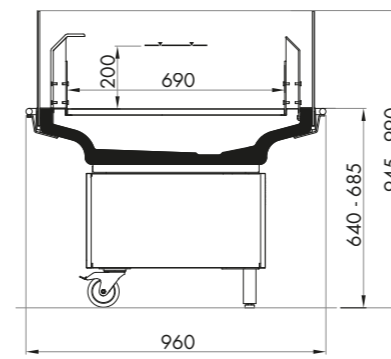

GIANO 70 VD

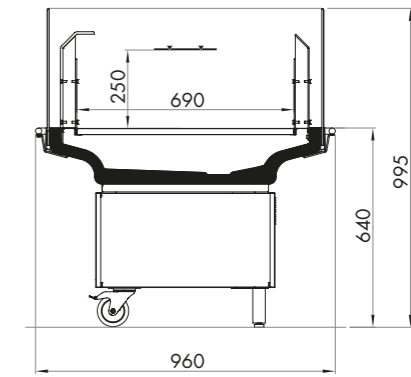

GIANO 70 MAXI

GIANO DA MINI A MAXI

GIANO
FROM MINI TO MAXI

GIANO
DE MINI À MAXI

GIANO
VON MINI BIS MAXI

GIANO
DE MINI A MAXI

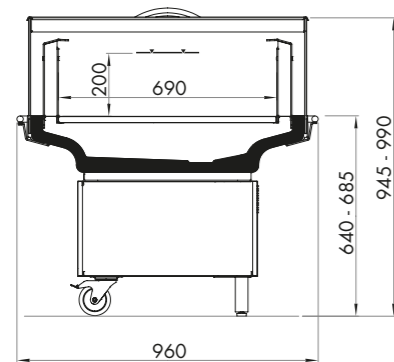

GIANO 70 VD GD

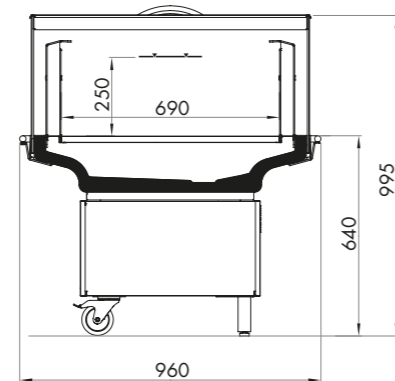

GIANO 70 MAXI GD

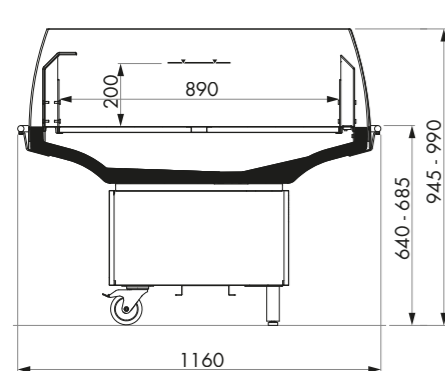

GIANO 90 VC

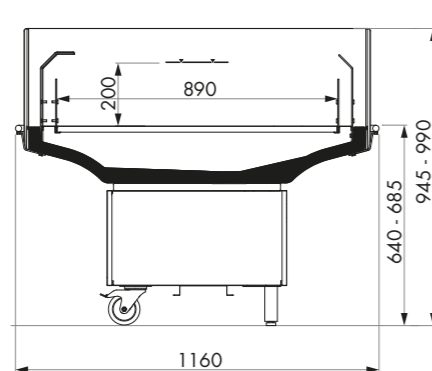

GIANO 90 VD

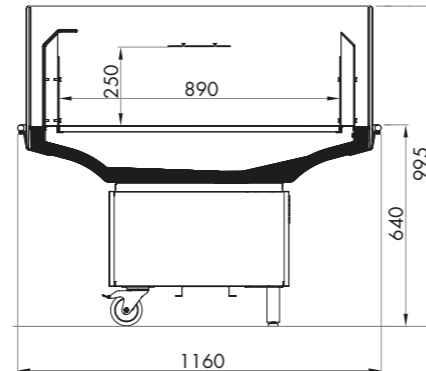

GIANO 90 MAXI

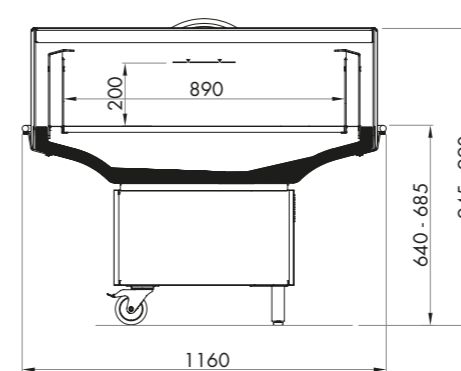

GIANO 90 VD GD

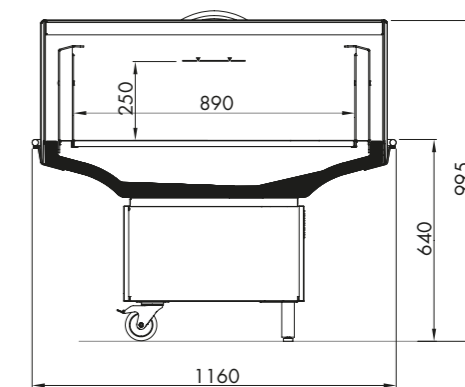

GIANO 90 MAXI GD

	Lunghezza (senza spalle) Length (without ends) Longueur (sans joues) Länge (ohne Seitenwände) Longitud (sin laterales)	Refrigerante Refrigerant Réfrigérant Kältemittel Refrigerante	Classe di temperatura Temperature class Classe de température Temperaturbereich Clase climática	Superficie espositiva Max. display area Surface max. d'exposition Maximale Auslagefläche Máxima superficie de exposición	Capacità di carico Volume capacity Volume utile Nutzinhalt Volumen útil	
	mm		*GD	m ²	dm ³	
Giano 50 VD	650	R290	3M2	3M1	0,34	68
	937	R290	3M2	3M1	0,49	98
Giano 70 VC	937	R290	3M2	-	0,65	130
	1250	R290	3M2	-	0,86	172
	1875	R290	3M2	-	1,29	259
Giano 70 VD	937	R290	3M2	3M1	0,65	130
	1250	R290	3M2	3M1	0,86	172
	1875	R290	3M2	3M1	1,29	259
Giano 70 Maxi	937	R290	3M2	3M0	0,65	162
	1250	R290	3M2	3M0	0,86	216
	1875	R290	3M2	3M0	1,29	323
Giano 90 VC	1250	R290	3M2	3M1	1,11	223
	2500	R290/R134a	3M2	3M1	2,23	445
Giano 90 VD	1250	R290	3M2	3M1	1,11	223
	2500	R290/R134a	3M2	3M1	2,23	445
Giano 90 Maxi	1250	R290	3M2	3M1	1,11	278
	2500	R290/R134a	3M2	3M1	2,23	556

* GD = con coperture vetro / with glass lids / mit Glasdeckel / avec couvercle vitrés / con tapas de cristal



Giano 50 VD 650

MASSIMA ADATTABILITÀ

Ingombri ridotti, forme moderne, disponibilità di più taglie

MAXIMUM ADAPTABILITY

Reduced dimensions, modern shapes, several sizes available

ADAPTABILITE MAXIMALE

Dimensions réduites, design contemporain, disponible dans plusieurs tailles

VIELFALT

Optimierte Abmessungen, einfache Formen, breite Auswahl an Modulen

MÁXIMA ADAPTABILIDAD

Cornisa reducida, líneas modernas, otras medidas disponibles



Giano 90 VD 1250



Giano 90 VC 1250



Giano 90 Maxi 2500

PERSONALIZZAZIONI

Base e interni disponibili in più colori, piedi e rivestimenti disponibili in più soluzioni

CUSTOMIZATION

Base and inner parts available in several colours, feet and claddings available in different solutions

PERSONNALISATION

Soubassement et intérieur disponibles en plusieurs couleurs, pieds et revêtements disponibles en plusieurs solutions

KUNDENINDIVIDUELL

Unterbauten und Auslagen in mehreren Farben und Varianten verfügbar.

PERSONALIZABLE

Color de cuba, patas y faldones standard y a medida



Controllore elettronico
Control panel
Régulateur électronique
Elektronische Steuerung
Controlador electrónico



Coperture scorrevoli
Couvercles vitrés
Glass lids
Glass Deckel
Tapas de cristal



Giano 90 Maxi GD 2500



GALILEI PLUG IN
TOTAL MODULARITY

1 PROGETTO

4 MODELLI

40 MODULI

∞ COMBINAZIONI

GALILEI PLUG IN
TOTAL MODULARITY

1 PROJECT

4 MODELS

40 MODULES

∞ COMBINATIONS

GALILEI PLUG IN
TOTAL MODULARITY

1 PROJET

4 MODELES

40 MODULES

∞ COMBINAISONS

GALILEI PLUG IN
TOTAL MODULARITY

1 PROJEKT

4 MODELLE

40 MODULEN

∞ KOMBINATIONEN

GALILEI PLUG IN
TOTAL MODULARITY

1 PLATAFORMA

4 FAMILIAS

40 MODELOS

∞ COMBINACIONES

VI
VISIBILITY
DE
DESIGN
RE
RELIABILITY

